

# **BIFURCATION PHENOMENA**

## Lecture 4: Bifurcations in $n$ -dimensional ODEs

Yuri A. Kuznetsov

August, 2010

# Contents

## 1. Solutions and orbits:

- equilibria
- cycles
- connecting orbits
- compact invariant manifolds
- strange invariant sets

## 2. Bifurcations of n-dimensional ODEs

- local equilibrium bifurcations
- local bifurcations of cycles
- bifurcations of homoclinic orbits to equilibria
- some other cases

## Literature

1. L.P. Shilnikov, A.L. Shilnikov, D.V. Turaev, and L.O. Chua *Methods of Qualitative Theory in Nonlinear Dynamics*, Part I, World Scientific, Singapore, 1998
2. L.P. Shilnikov, A.L. Shilnikov, D.V. Turaev, and L.O. Chua *Methods of Qualitative Theory in Nonlinear Dynamics*, Part II, World Scientific, Singapore, 2001
3. V.I. Arnol'd, V.S. Afraimovich, Yu.S. Il'yashenko, and L.P. Shil'nikov *Bifurcation theory*, In: V.I. Arnol'd (ed), *Dynamical Systems V. Encyclopaedia of Mathematical Sciences*, Springer-Verlag, New York, 1994
4. Yu.A. Kuznetsov *Elements of Applied Bifurcation Theory*, 3rd ed. Applied Mathematical Sciences 112, Springer-Verlag, New York, 2004
5. Yu.A. Kuznetsov, O. De Feo, and S. Rinaldi (2001), Belyakov homoclinic bifurcations in a tritrophic food chain model, *SIAM J. Appl. Math.* **62**, 462–487

# 1. SOLUTIONS AND ORBITS

Consider a smooth system

$$\dot{X} = f(X), \quad X \in \mathbb{R}^n.$$

**Orbits, phase portraits, and topological equivalence** are defined as in the case  $n = 2$

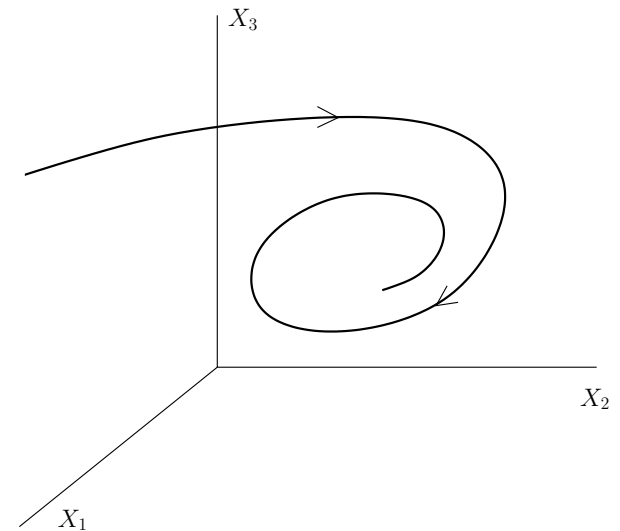

- **Equilibria:**  $f(X_0) = 0$

**Definition 1** An equilibrium is called **hyperbolic** if  $\Re(\lambda) \neq 0$  for all eigenvalues of its Jacobian matrix  $A = f_X(X_0)$ .

**Theorem 1 (Grobman-Hartman)** If equilibrium  $X_0 = 0$  is hyperbolic,  $\dot{X} = f(X)$  is locally topologically equivalent near the origin to  $\dot{Y} = AY$ .

## Stable and unstable invariant manifolds of equilibria:

If a hyperbolic equilibrium  $X_0$  has  $n_s$  eigenvalues with  $\Re(\lambda) < 0$  and  $n_u$  eigenvalues with  $\Re(\lambda) > 0$ , it has the  $n_s$ -dimensional smooth invariant manifold  $W^s$  composed of all orbits approaching  $X_0$  as  $t \rightarrow \infty$ , and the  $n_u$ -dimensional smooth invariant manifold  $W^u$  composed of all orbits approaching  $X_0$  as  $t \rightarrow -\infty$

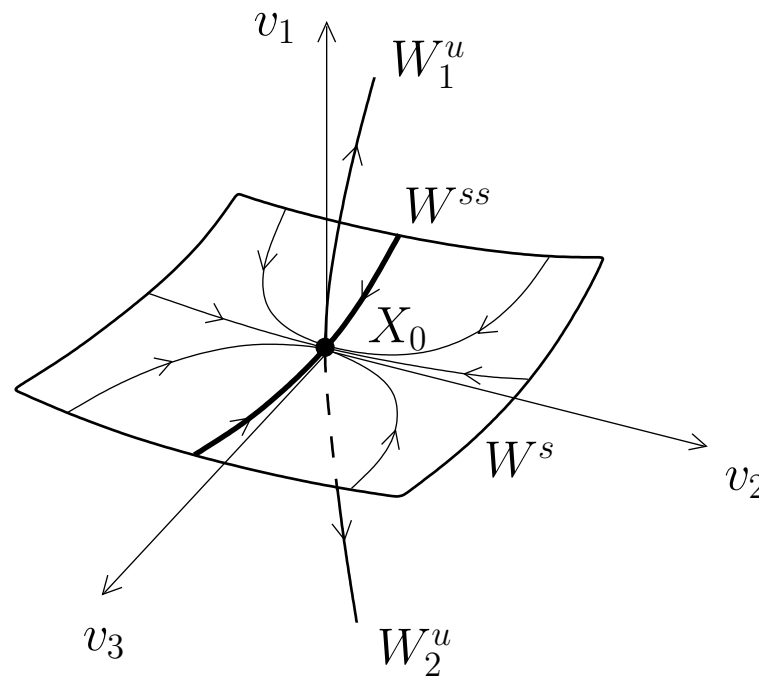
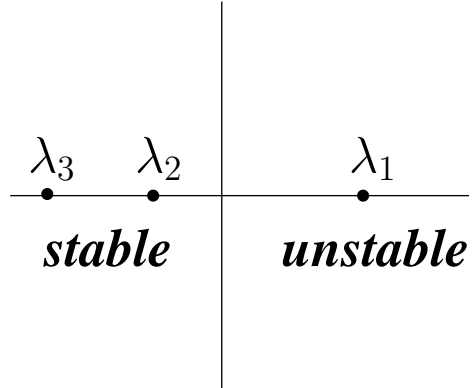

$$Av_j = \lambda_j v_j$$

- **Periodic orbits (cycles)**

The **Poincaré map**  $\xi \mapsto \tilde{\xi} = P(\xi)$  is defined on a smooth  $(n - 1)$ -dimensional cross-section:

$$P : \Sigma \rightarrow \Sigma.$$

If  $C_0$  corresponds to  $\xi = 0$  then  $P(0) = 0$  and  $P(\xi) = M\xi + O(2)$

$$\mu_1 \mu_2 \cdots \mu_{n-1} = \exp \left( \int_0^{T_0} (\operatorname{div} f)(X^0(t)) dt \right) > 0$$

**Definition 2** A cycle is called **hyperbolic** if  $|\mu| \neq 1$  for all eigenvalues (multipliers) of the matrix  $M = P_\xi(0)$ .

**Theorem 2 (Grobman-Hartman for maps)** The Poincaré map  $\xi \mapsto P(\xi)$  of a hyperbolic cycle is locally topologically equivalent near the origin to  $\xi \mapsto M\xi$ .

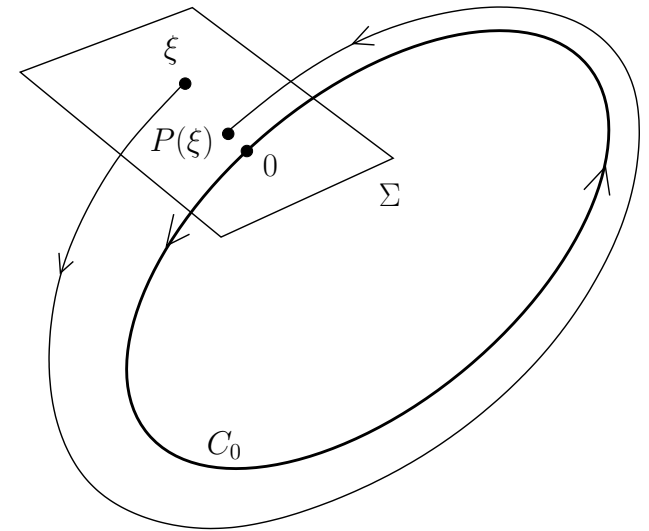

## Stable and unstable invariant manifolds of cycles:

If a hyperbolic cycle  $C_0$  has  $m_s$  multipliers with  $|\mu| < 1$  and  $m_u$  multipliers with  $|\mu| > 1$ , it has the  $(m_s + 1)$ -dimensional smooth invariant manifold  $W^s$  composed of all orbits approaching  $C_0$  as  $t \rightarrow \infty$ , and the  $(m_u + 1)$ -dimensional smooth invariant manifold  $W^u$  composed of all orbits approaching  $C_0$  as  $t \rightarrow -\infty$

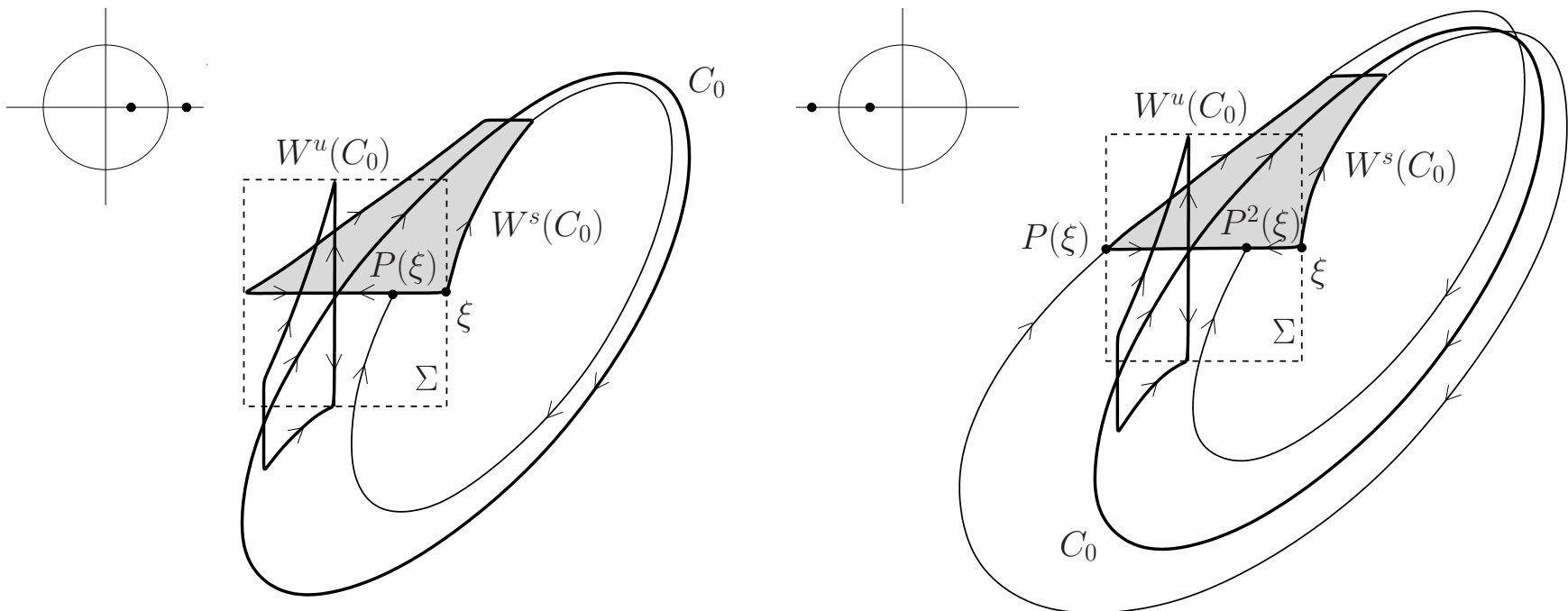

- **Connecting orbits**

**Homoclinic orbits** are intersections of  $W^u$  and  $W^s$  of an equilibrium/cycle.  
**Heteroclinic orbits** are intersections of  $W^u$  and  $W^s$  of two different equilibria/cycles.

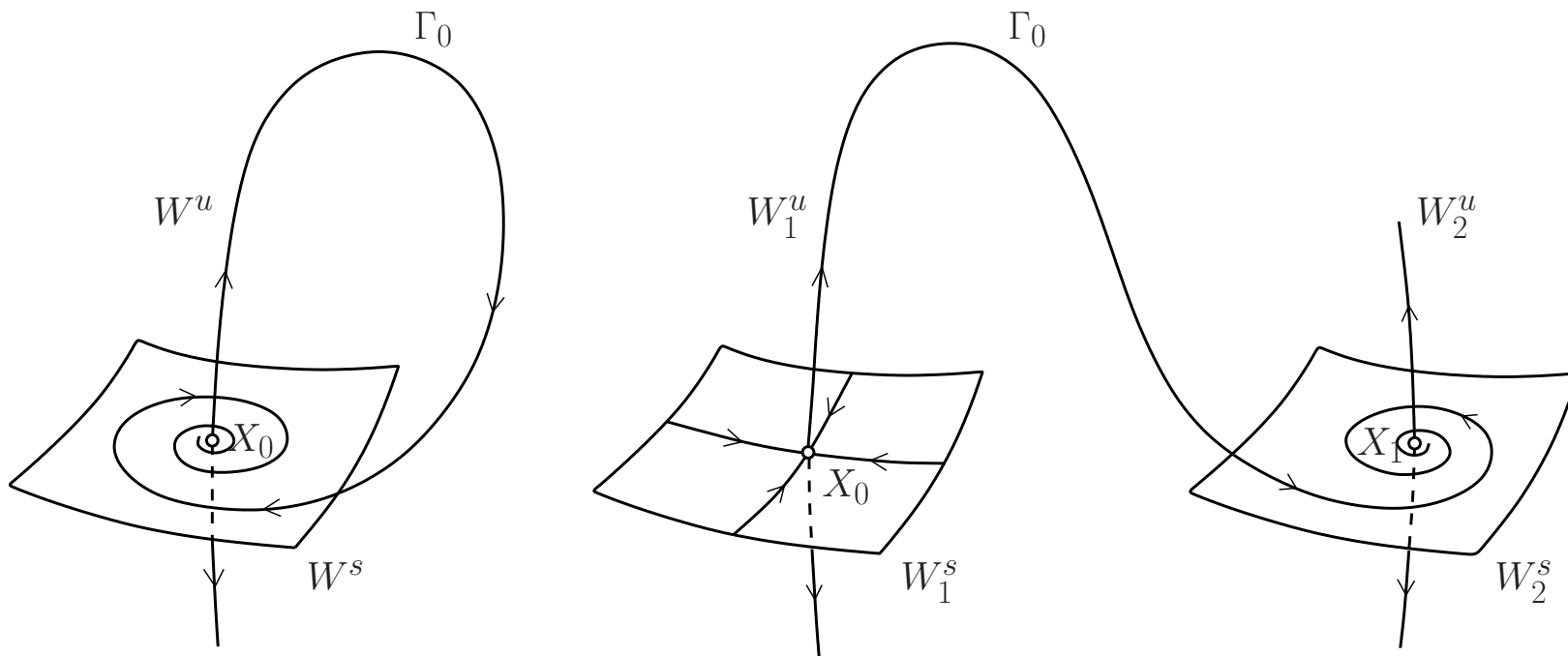

Generically, the closure of the 2D invariant manifold near a homoclinic orbit  $\Gamma_0$  to an equilibrium with real eigenvalues (**saddle**) in  $\mathbb{R}^3$  is either **simple (orientable)** or **twisted (non-orientable)**:

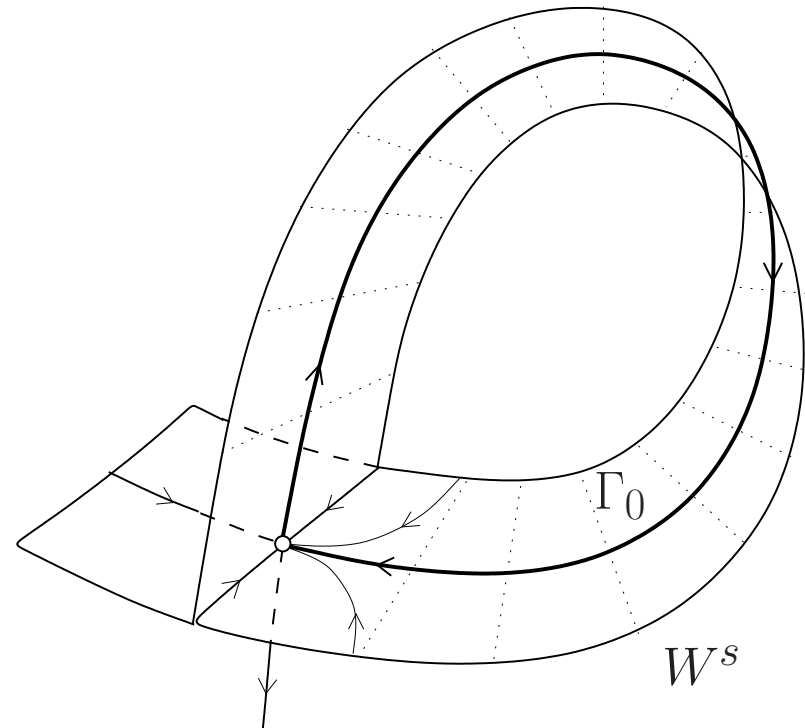
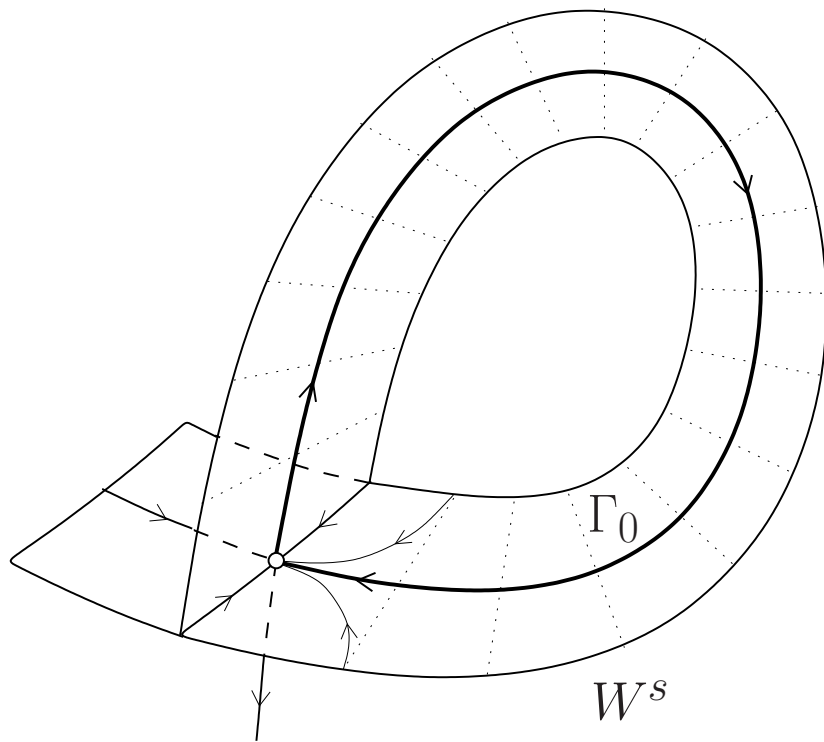

- **Compact invariant manifolds**

1. tori

**Example:** 2D-torus  $\mathbb{T}^2$  with periodic or quasi-periodic orbits

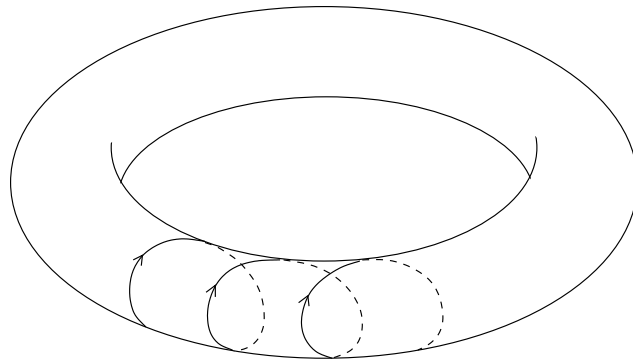

2. spheres

3. Klein bottles

- **Strange (chaotic) invariant sets**

- have **fractal** structure (not a manifold);
- contain **infinite** number of hyperbolic cycles;
- demonstrate **sensitive dependence** of solutions on initial conditions;
- can be attracting (**strange attractors**);
- orbits can be coded by sequences of symbols (**symbolic dynamics**).

## 2. BIFURCATIONS OF N-DIMENSIONAL ODES $\dot{X} = f(X, \alpha)$

- **Local (equilibrium) bifurcations**

**Center manifold reduction:** Let  $X_0 = 0$  be non-hyperbolic with stable, unstable, and critical eigenvalues:

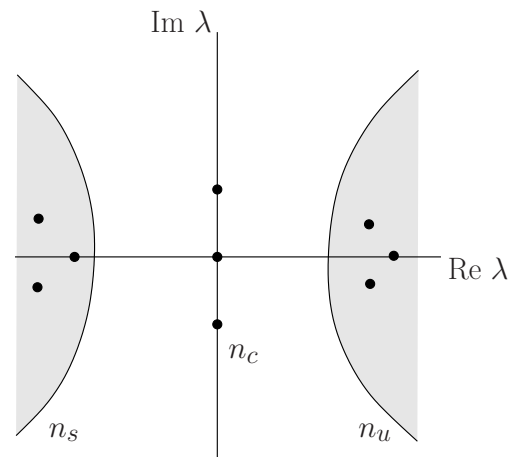

**Theorem 3** For all sufficiently small  $\|\alpha\|$ , there exists a local invariant center manifold  $W^c(\alpha)$  of dimension  $n_c$  that is locally attracting if  $n_u = 0$ , repelling if  $n_s = 0$ , and of saddle type if  $n_s n_u > 0$ . Moreover  $W^c(0)$  is tangent to the critical eigenspace of  $A = f_X(0, 0)$ .

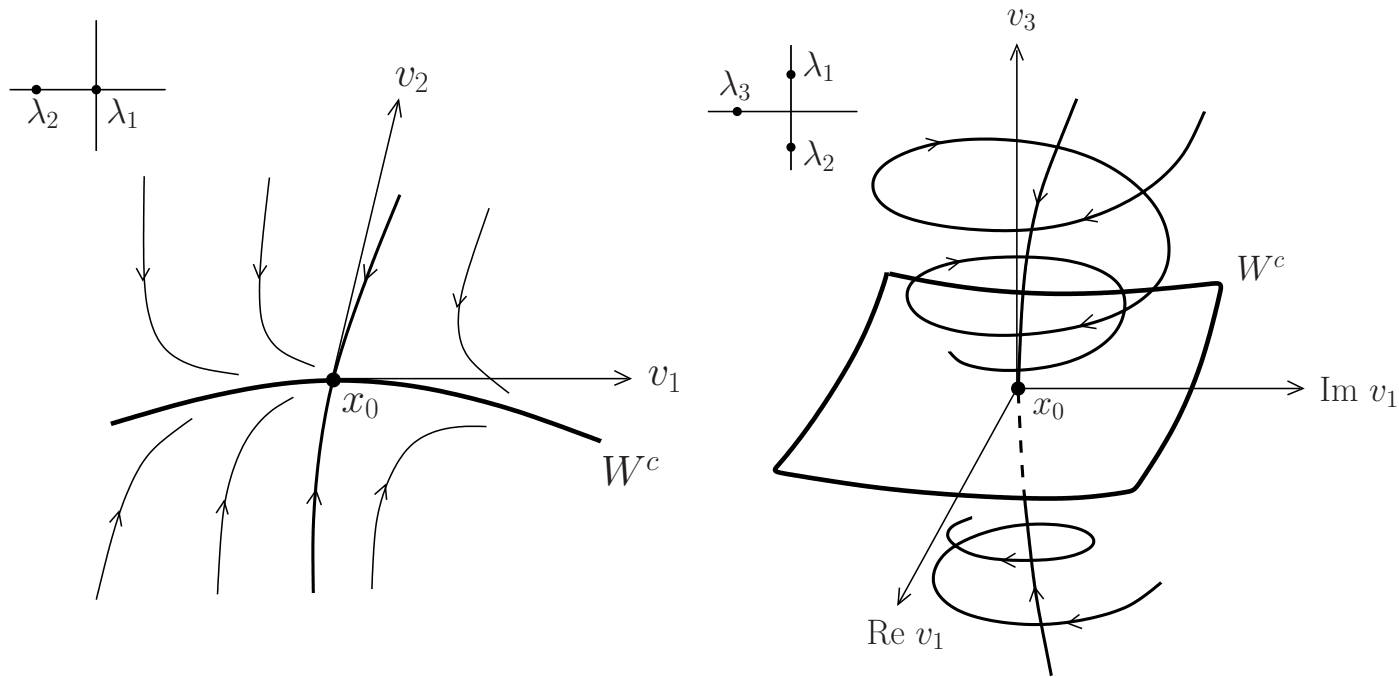

**Remark:**  $W^c(0)$  is **not unique**; however, all  $W^c(0)$  have the same Taylor expansion.

**Theorem 4** If  $\dot{\xi} = f(\xi, \alpha)$  is the restriction of  $\dot{X} = f(X, \alpha)$  to  $W^c(\alpha)$ , then this system is locally topologically equivalent to

$$\begin{cases} \dot{\xi} = f(\xi, \alpha), & \xi \in \mathbb{R}^{n_c}, \alpha \in \mathbb{R}^m, \\ \dot{x} = -x, & x \in \mathbb{R}^{n_s}, \\ \dot{y} = y, & y \in \mathbb{R}^{n_u}. \end{cases}$$

**Codim 1 equilibrium bifurcations:**  $\alpha \in \mathbb{R}$

$$f(X, 0) = AX + \frac{1}{2}B(X, X) + \frac{1}{6}C(X, X, X) + O(4)$$

- **Fold (saddle-node):**  $\lambda_1 = 0$  ( $n_c = 1$ )

Let  $a = \frac{1}{2}\langle q, B(q, q) \rangle$  where  $Aq = A^T p = 0$  with  $\langle p, q \rangle = \langle q, q \rangle = 1$ .

If  $a \neq 0$  then the restriction of  $\dot{X} = f(X, \alpha)$  to its  $W^c(\alpha)$  is locally topologically equivalent to  $\dot{\xi} = \beta(\alpha) + a\xi^2$ .

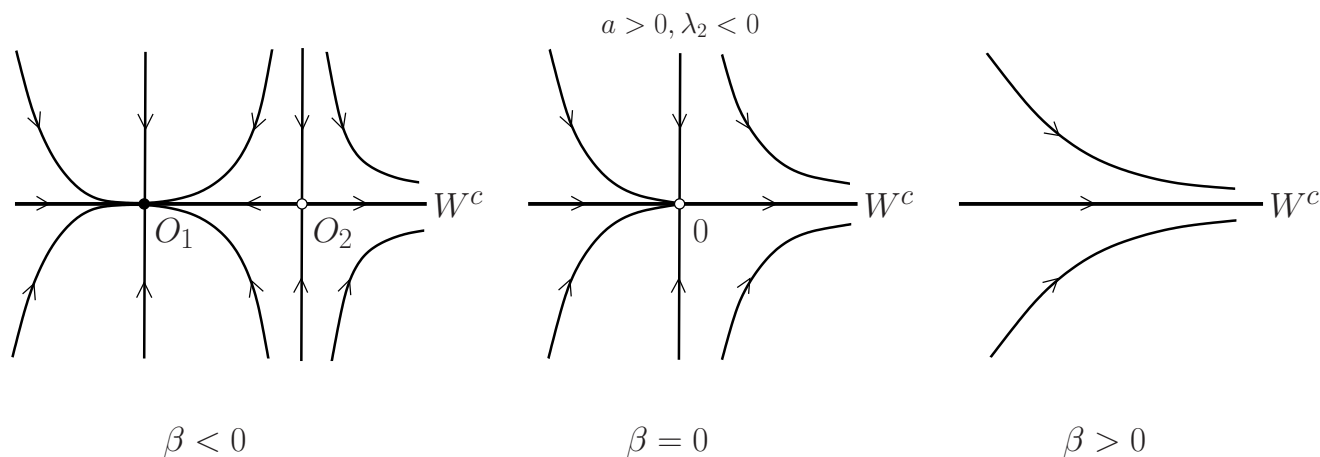

- **Andronov-Hopf:**  $\lambda_{1,2} = \pm i\omega, \omega > 0$  ( $n_c = 2$ )

$$l_1 = \frac{1}{2\omega} \Re \left[ \langle p, C(q, q, \bar{q}) - 2\langle p, B(q, A^{-1}B(q, \bar{q})) \rangle + \langle p, B(\bar{q}, (2i\omega E_n - A)^{-1}B(q, q)) \rangle \right],$$

where  $Aq = i\omega q$ ,  $A^T p = -i\omega p$ ,  $\langle p, q \rangle = \langle q, q \rangle = 1$ .

If  $l_1 \neq 0$  then the restriction of  $\dot{X} = f(X, \alpha)$  to its  $W^c(\alpha)$  is locally topologically equivalent to  $\begin{cases} \dot{\rho} = \rho(\beta(\alpha) + l_1\rho^2), \\ \dot{\varphi} = 1. \end{cases}$

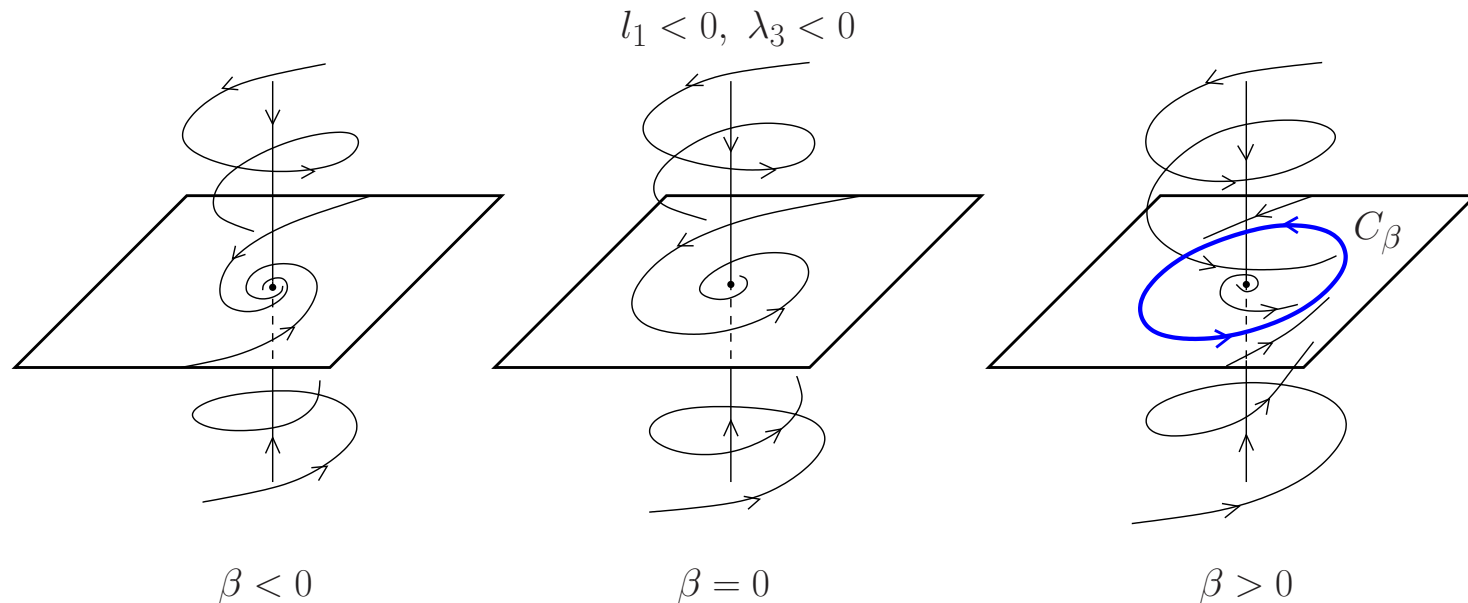

## Codim 2 equilibrium bifurcations: $\alpha \in \mathbb{R}^2$

### 1. **Cusp:** $\lambda_1 = 0, a = 0$ ( $n_c = 1$ )

If  $c \neq 0$ , then the restriction of  $\dot{X} = f(X, \alpha)$  to  $W^c(\alpha)$  is locally topologically equivalent to  $\dot{\xi} = \beta_1(\alpha) + \beta_2(\alpha)\xi + s\xi^3$ , where  $s = \text{sign}(c) = \pm 1$ .

### 2. **Bogdanov-Takens:** $\lambda_1 = \lambda_2 = 0$ ( $n_c = 2$ )

If  $ab \neq 0$ , then the restriction of  $\dot{X} = f(X, \alpha)$  to  $W^c(\alpha)$  is locally topologically equivalent to  $\dot{x} = y, \dot{y} = \beta_1(\alpha) + \beta_2(\alpha)x + x^2 + sxy$ , where  $s = \text{sign}(ab) = \pm 1$ .

### 3. **Bautin:** $\lambda_{1,2} = \pm i\omega, \omega > 0$ ( $n_c = 2$ )

If  $l_2 \neq 0$ , then the restriction of  $\dot{X} = f(X, \alpha)$  to  $W^c(\alpha)$  is locally topologically equivalent to  $\dot{\rho} = \rho(\beta_1(\alpha) + \beta_2(\alpha)\rho^2 + s\rho^4), \dot{\varphi} = 1$ , where  $s = \text{sign}(l_2) = \pm 1$ .

4. **Fold-Hopf:**  $\lambda_1 = 0, \lambda_{2,3} = \pm i\omega, \omega > 0$  ( $n_c = 3$ )

Generically, the restriction of  $\dot{X} = f(X, \alpha)$  to  $W^c(\alpha)$  is smoothly orbitally equivalent to

$$\begin{cases} \dot{\xi} &= \beta_1(\alpha) + \xi^2 + s\rho^2 + P(\xi, \rho, \varphi, \alpha), \\ \dot{\rho} &= \rho(\beta_2(\alpha) + \theta(\alpha)\xi + \xi^2) + Q(\xi, \rho, \varphi, \alpha), \\ \dot{\varphi} &= \omega_1(\alpha) + \theta_1(\alpha)\xi + R(\xi, \rho, \varphi, \alpha), \end{cases}$$

where  $s = \pm 1, \theta(0) \neq 0, \omega_1(0) > 0, P, Q, R = \mathcal{O}(\|(\xi, \rho)\|^4)$ .

The bifurcation diagrams **depend on**  $O(4)$ -terms. “Big picture” is determined by the ‘truncated normal form’ without the  $O(4)$ -terms.

There exist **invariant tori** and **homoclinic orbits** near the fold-Hopf bifurcation.

5. **Hopf-Hopf:**  $\lambda_{1,2} = \pm i\omega_1$ ,  $\lambda_{3,4} = \pm i\omega_2$ ,  $\omega_j > 0$  ( $n_c = 4$ )

Generically, the restriction of  $\dot{X} = f(X, \alpha)$  to  $W^c(\alpha)$  is smoothly orbitally equivalent to

$$\begin{cases} \dot{r}_1 &= r_1(\beta_1(\alpha) + p_{11}(\alpha)r_1^2 + p_{12}(\alpha)r_2^2 + s_1(\alpha)r_2^4) + \Phi_1(r, \varphi, \alpha), \\ \dot{r}_2 &= r_2(\beta_2(\alpha) + p_{21}(\alpha)r_1^2 + p_{22}(\alpha)r_2^2 + s_2(\alpha)r_1^4) + \Phi_2(r, \varphi, \alpha), \\ \dot{\varphi}_1 &= \omega_1(\alpha) + \Psi_1(r, \varphi, \alpha), \\ \dot{\varphi}_2 &= \omega_2(\alpha) + \Psi_2(r, \varphi, \alpha) \end{cases}$$

where  $\Phi_j = \mathcal{O}(\|r\|^6)$ ,  $\Psi_j = \mathcal{O}(\|r\|)$ .

The bifurcation diagrams **depend on**  $\Phi_j$ - and  $\Psi_j$ -terms. “Big picture” is determined by the ‘truncated normal form’ without these terms.

There exist **invariant tori** and **homoclinic orbits** near the Hopf-Hopf bifurcation.

## Local bifurcations of cycles

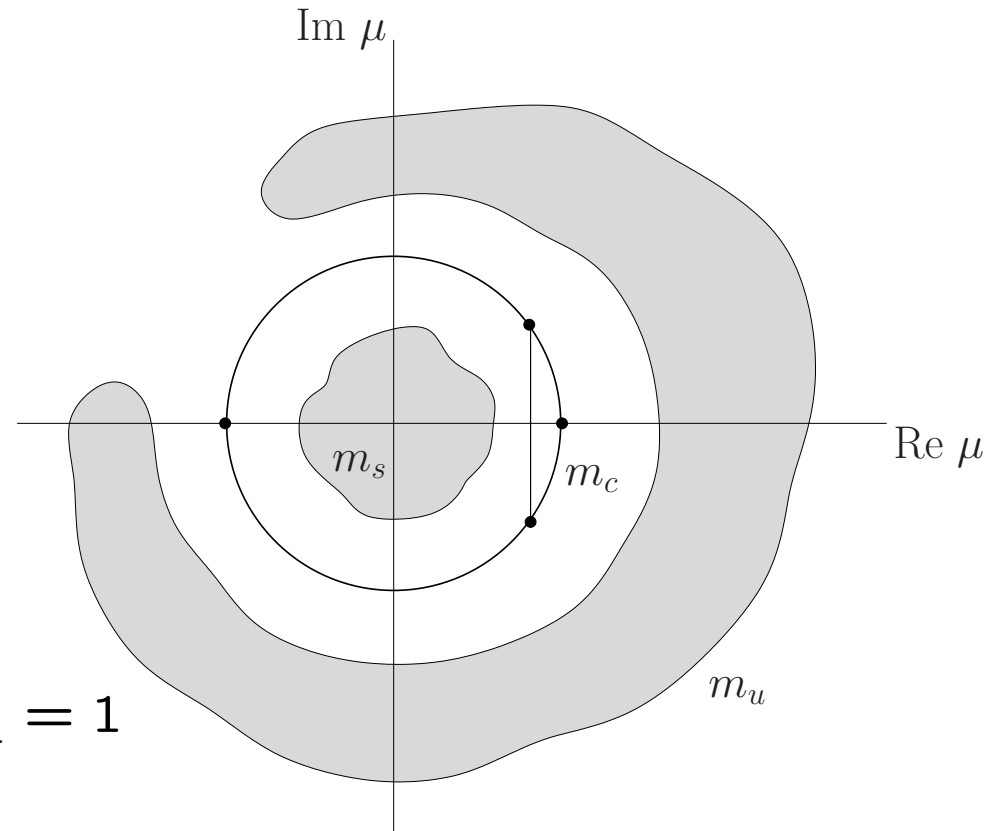

### Critical cases of codim 1:

- cyclic fold (saddle-node):  $\mu_1 = 1$
- period-doubling:  $\mu_1 = -1$
- Neimark-Sacker (torus):  $\mu_{1,2} = e^{\pm i\theta}$ ,  $0 < \theta < \pi$

- **Fold bifurcation of cycles:**  $\mu_1 = 1$  ( $m_c = 1$ )

If  $b \neq 0$  then the restriction of the Poincaré map to its  $W^c(\alpha)$  is locally topologically equivalent to  $\xi \mapsto \tilde{\xi} = \xi + \beta(\alpha) + a\xi^2$ .

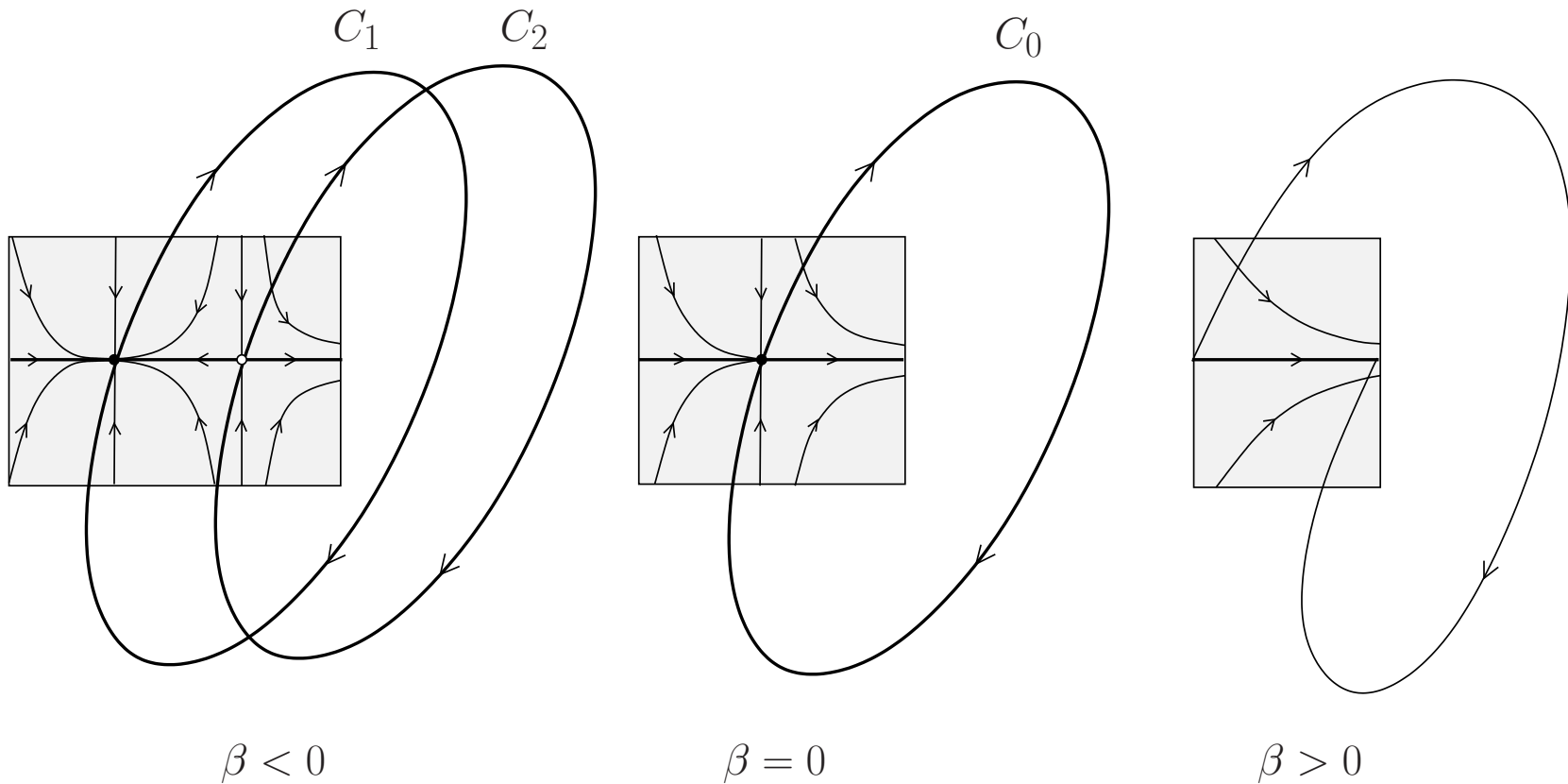

• **Period-doubling:**  $\mu_1 = -1$  ( $m_c = 1$ )

If  $c \neq 0$  then the restriction of the Poincaré map to its  $W^c(\alpha)$  is locally topologically equivalent to  $\xi \mapsto \tilde{\xi} = -(1 + \beta(\alpha))\xi + c\xi^3$ .

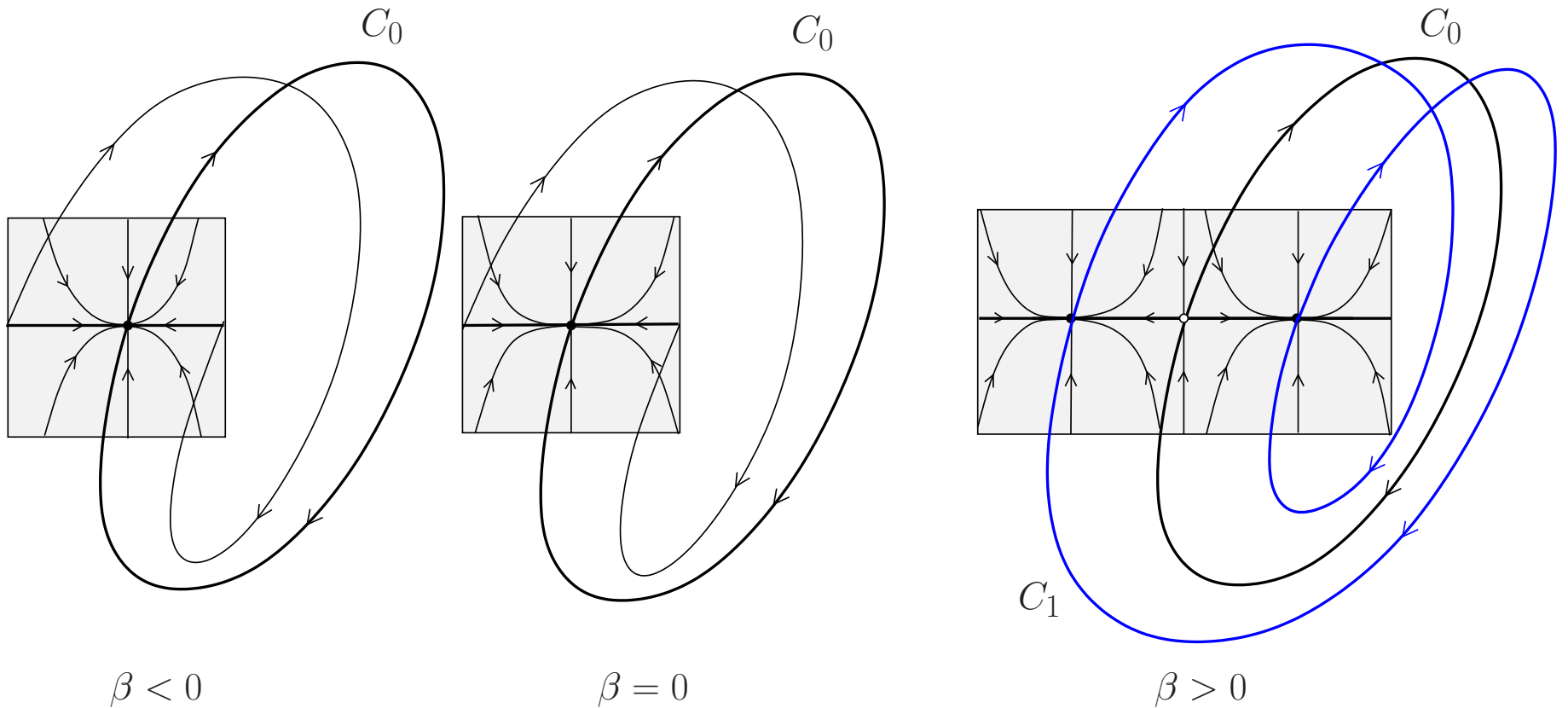

- **Torus:**  $\mu_1 = -1$  ( $m_c = 1$ )

If  $d(0) \neq 0$  and  $e^{ik\theta} \neq 1$  for  $k = 1, 2, 3, 4$ , then the restriction of the Poincaré map to its  $W^c(\alpha)$  is locally smoothly equivalent to

$$\begin{pmatrix} \rho \\ \varphi \end{pmatrix} \mapsto \begin{pmatrix} \rho(1 + \beta(\alpha) + d(\alpha)\rho^2) \\ \varphi + \theta(\alpha) \end{pmatrix} + \begin{pmatrix} R(\rho, \varphi, \alpha) \\ S(\rho, \varphi, \alpha) \end{pmatrix},$$

where  $R = O(\rho^4)$ ,  $S = O(\rho^2)$

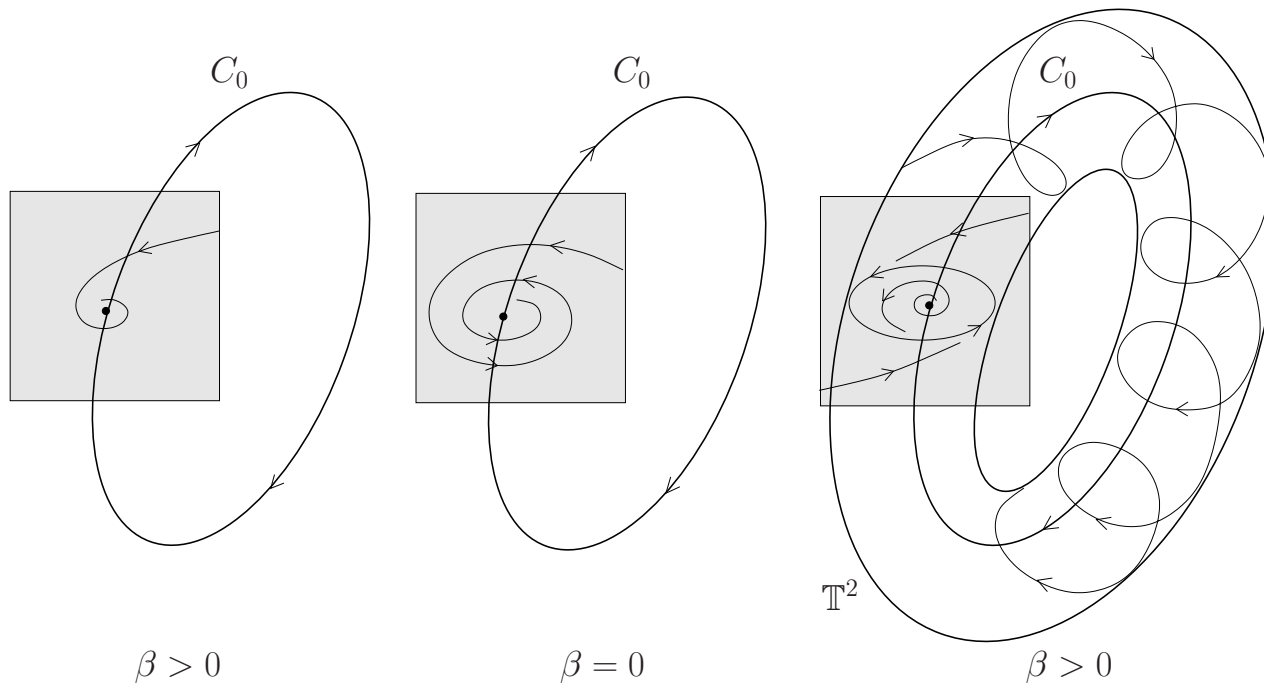

## Codim1 bifurcations of homoclinic orbits to equilibria

- Homoclinic orbit to a hyperbolic equilibrium:

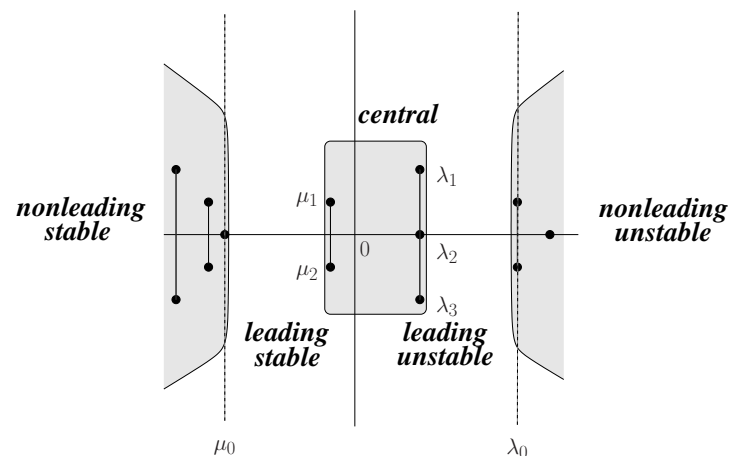

**Definition 3 Saddle quantity**  $\sigma = \Re(\mu_1) + \Re(\lambda_1)$ .

**Theorem 5 (Homoclinic Center Manifold)** *Generically, there exists an invariant finitely-smooth manifold  $W^h(\alpha)$  that is tangent to the central eigenspace at the homoclinic bifurcation.*

**Saddle homoclinic orbit:**  $\sigma = \mu_1 + \lambda_1$

Assume that  $\Gamma_0$  approaches  $X_0$  along the leading eigenvectors.

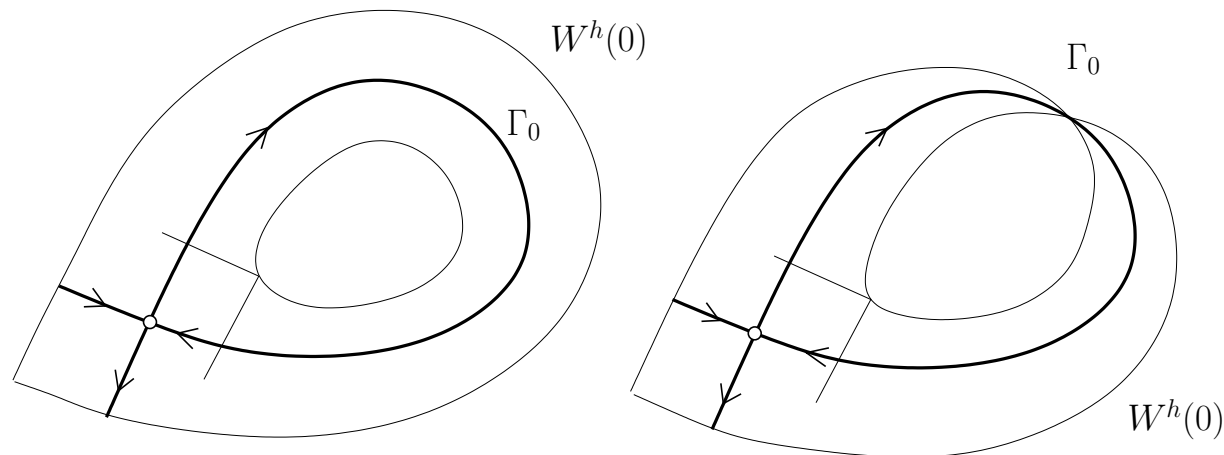

The Poincaré map near  $\Gamma_0$ :

$$\xi \mapsto \tilde{\xi} = \beta + A\xi^{-\frac{\mu_1}{\lambda_1}} + \dots$$

where generically  $A \neq 0$ , so that a unique hyperbolic cycle bifurcates from  $\Gamma_0$  (stable in  $W^h$  if  $\sigma < 0$  and unstable in  $W^h$  if  $\sigma > 0$ ).

### 3D saddle homoclinic bifurcation with $\sigma < 0$ :

Assume that  $\mu_2 < \mu_1 < 0 < \lambda_1$  (otherwise reverse time:  $t \mapsto -t$ ).

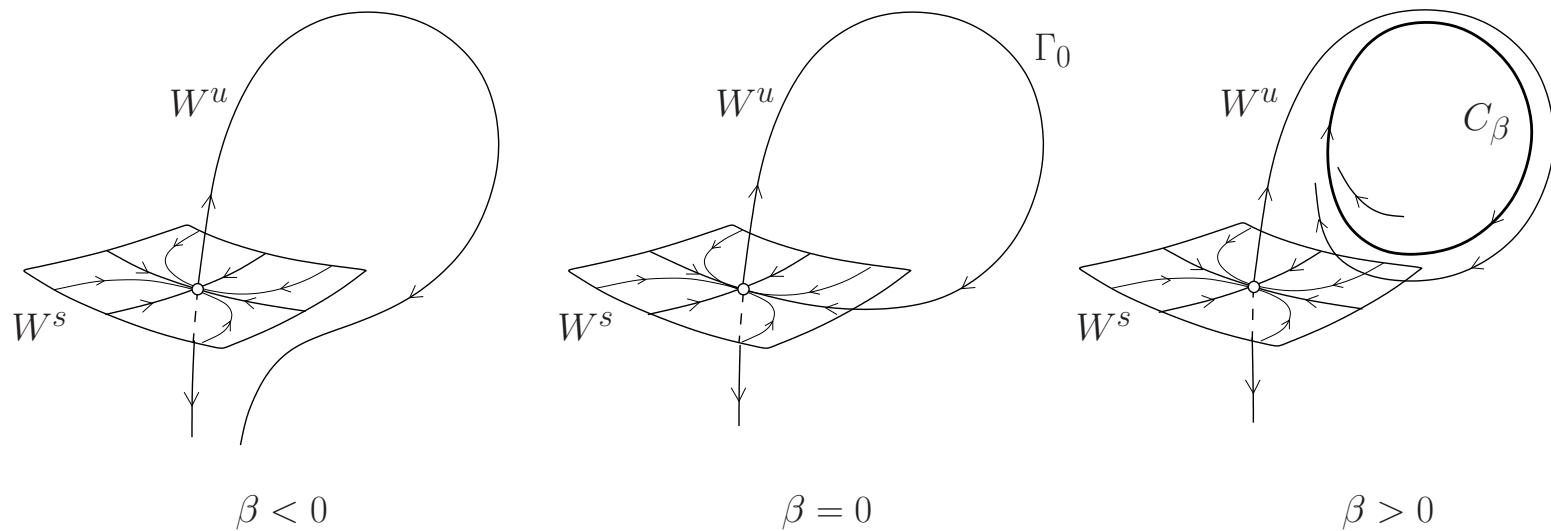

### 3D saddle homoclinic bifurcation with $\sigma > 0$ :

Assume that  $\mu_2 < \mu_1 < 0 < \lambda_1$  (otherwise reverse time:  $t \mapsto -t$ ).

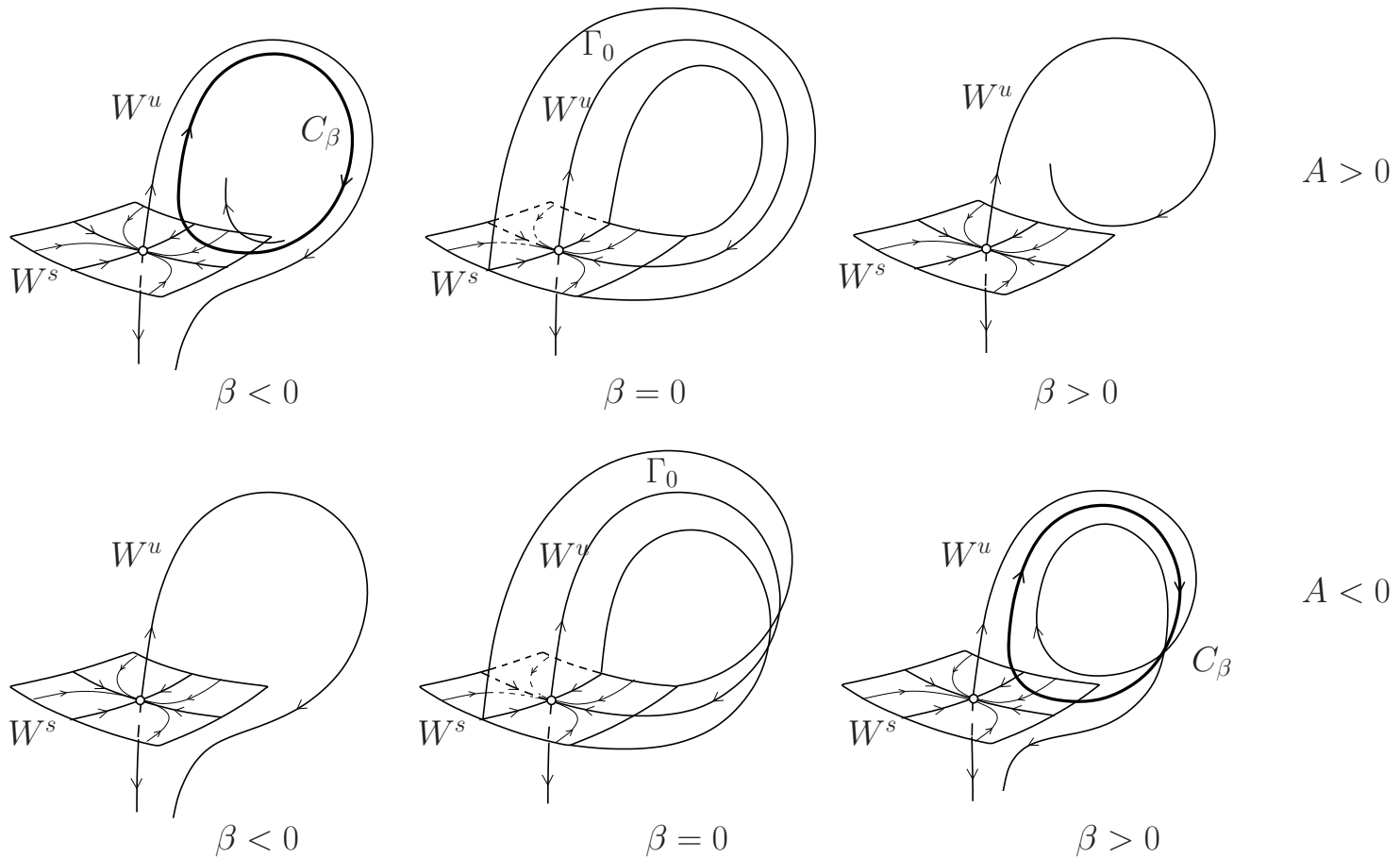

**Saddle-focus homoclinic orbit:**  $\sigma = \Re(\mu_1) + \lambda_1$

**3D saddle-focus homoclinic bifurcation with  $\sigma < 0$ :**

Assume that  $\Re(\mu_2) = \Re(\mu_1) < 0 < \lambda_1$  (otherwise reverse time:  $t \mapsto -t$ ).

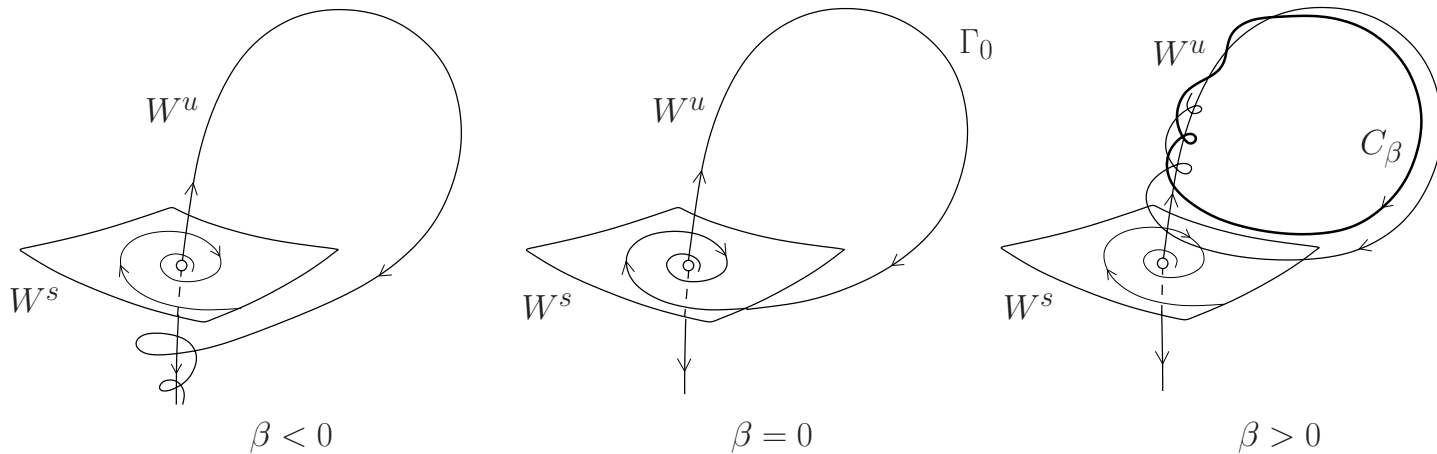

**3D saddle-focus homoclinic bifurcation with  $\sigma > 0$ :**

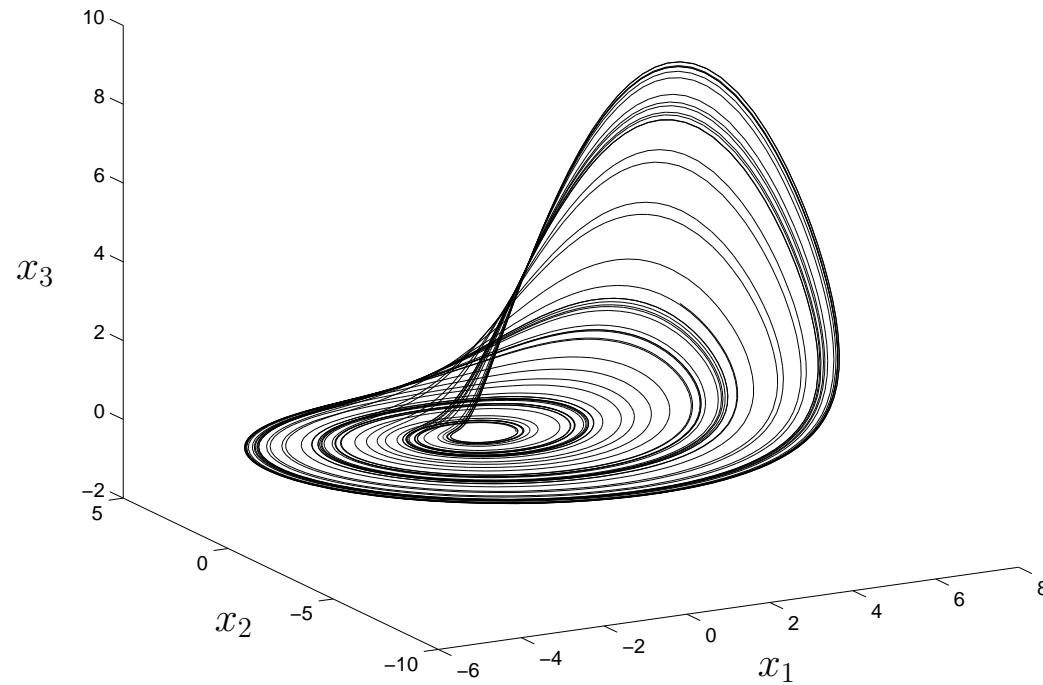

**CHAOTIC INVARIANT SET**

**Focus-focus homoclinic orbit:  $\sigma = \Re(\mu_1) + \Re(\lambda_1)$**

**CHAOTIC INVARIANT SET**

- **Homoclinic orbit(s) to a non-hyperbolic equilibrium**

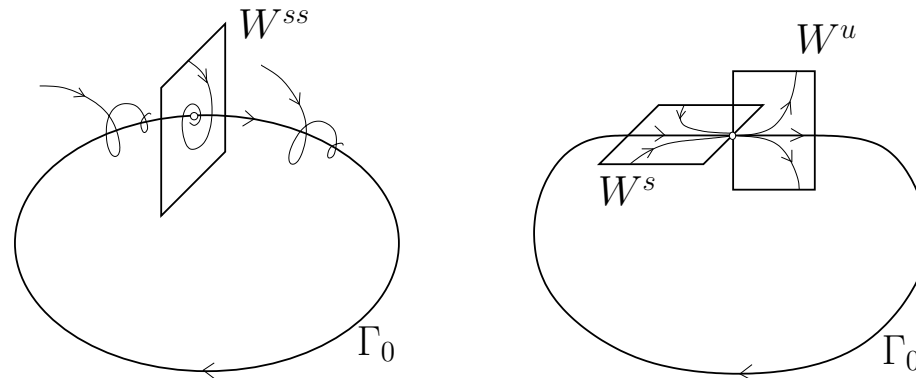

**One homoclinic orbit:  $\Rightarrow$  a unique hyperbolic cycle**

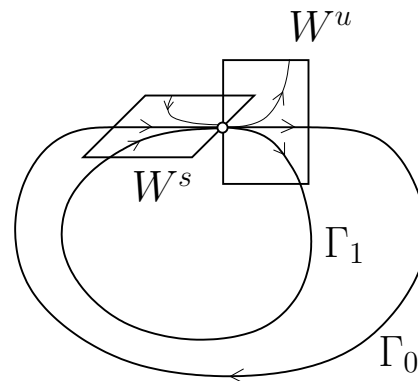

**Several homoclinic orbits:  $\Rightarrow$  CHAOTIC INVARIANT SET**

- Some other cases

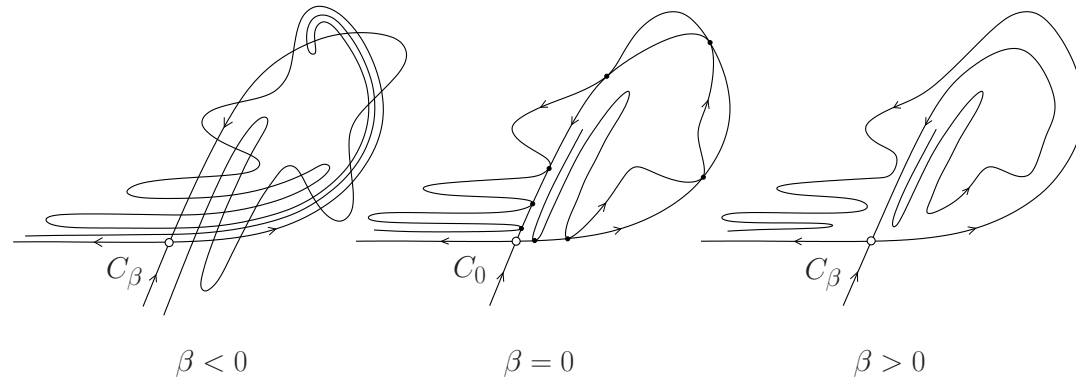

**Homoclinic tangency of a hyperbolic cycle:  $\Rightarrow$  CHAOS**

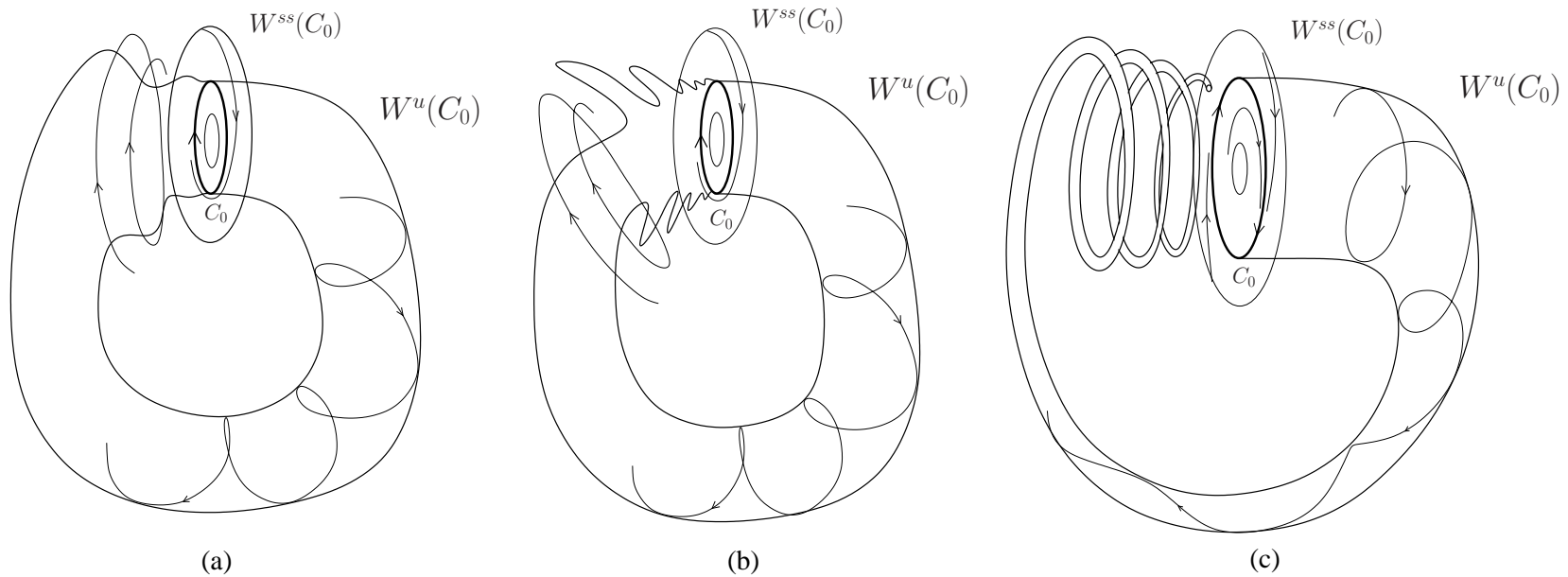

**Homoclinics to nonhyperbolic cycle:  $\Rightarrow$  torus/CHAOS/cycle**

## Example: Bifurcations in a food chain model

- The tri-trophic food chain model by Hogeweg & Hesper (1978):

$$\begin{cases} \dot{x}_1 &= rx_1 \left(1 - \frac{x_1}{K}\right) - \frac{a_1 x_1 x_2}{1 + b_1 x_1}, \\ \dot{x}_2 &= e_1 \frac{a_1 x_1 x_2}{1 + b_1 x_1} - \frac{a_2 x_2 x_3}{1 + b_2 x_2} - d_1 x_2, \\ \dot{x}_3 &= e_2 \frac{a_2 x_2 x_3}{1 + b_2 x_2} - d_2 x_3, \end{cases}$$

where

$x_1$  prey biomass  
 $x_2$  predator biomass  
 $x_3$  super-predator biomass

# Local bifurcations

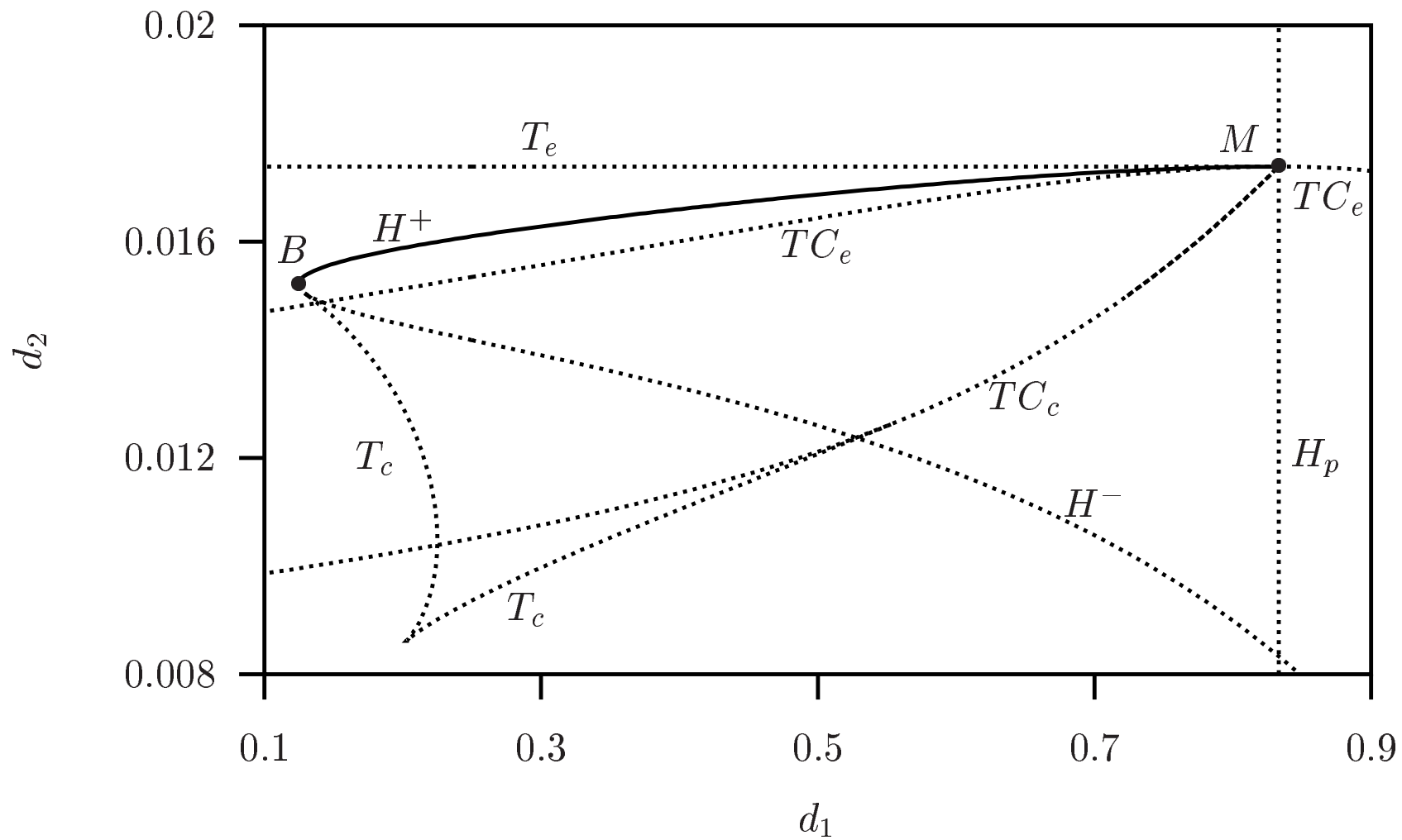

# Local and key global bifurcations

